



Since 1948

IntelliCable® Alley Scraper

Keep your herd clean with the push of a button!

Automatically clean on a precise schedule – even while you sleep!

- Advanced SmartSense® learning system constantly adjusts to weather, bedding, and manure changes while recalculating the amount of torque needed to pull to the drop point.
- Energy-efficient drive system!
- Drive unit design includes technology for precise scraper automation!
- Scrapers designed for easy removal.
- Easily installs in existing or new barns!
- Low maintenance!



Pro I



Pro II

Programmable BUMP FEATURE provides superior sensitivity!



Pro III

Let Patz handle your manure so you don't have to!

For concrete alleys or rubber flooring!

MANURE SOLUTIONS
www.patzcorp.com

Improve your bottom line with !

- Reduce expenses with time, labor, and energy savings.
- Minimize wear on tractor/skid-steer and facilities.
- Clean more often.
- Reduce livestock stress with quiet, emissions-free cleaning!

“We run the scrapers continuously to keep the cows as clean as possible - a key factor in keeping SCC low and herd health high.”
-WI Dairy Farmer

High quality milk starts with cleaner, calmer cows!



SmartSense® MasterMind Control Panel

Provides the quality and safety features you want for your employees and family.

- Fiberglass enclosure.
- Glove-friendly, easy-to-use, 5.7" (145 mm) black and white touch screen display.
- 3 operational modes: MANual, CONTinuous, and AUTOMatic (schedule up to 12 cycles per day).
- Adjustable speed control.
- Superior sensitivity - programmable BUMP feature.
- Patz innovative "Learning System."
- Faults and services are stored in memory to allow service technicians to quickly pinpoint problems.
- Easy-to-use, quick-connect electric cables with pre-wired junction box.
- Integrated LOCK-OUT/TAG-OUT power disconnect lever.
- HARD PULL one-button feature works great for freshly bedded alleys and times of heavy or excessive manure.
- PARK feature keeps scrapers out of way when needed (designate alternate scraper location other than HOME).
- QUICK CLEAN feature cleans alley in between scheduled cleanings.
- Easy-to-understand pictorial icons.
- Black plastic manual box included to protect Operator's and Parts Manuals from the environment.

Save steps and labor when you control all functions of the IntelliCable® Alley Scraper at the

SmartSense®
Control Panel



Available in:
1Ø or 3Ø, 230 V power, 50/60 Hz.
Higher voltage option available.

SmartSense® Control Panel features an easy-to-use, "glove-friendly" touch screen.

**FLEXIBLE PAYMENT
PLANS AVAILABLE.
ASK FOR DETAILS.**



IntelliCable® Drive Units

IntelliCable® Pro I

- 1-hp electric motor
- 60:1 worm gear speed reducer
- #80 roller chain drive
- 29½" (749 mm) diameter solid drive drum - 18" (457 mm) wide
- 1 cable over wrap switch
- 2" (51 mm) replaceable drive drum shaft
- External grease fittings
- Safety interlock
- 3/8", 7/16", & 1/2" O.D. cable
- Sensor disc and proximity sensors

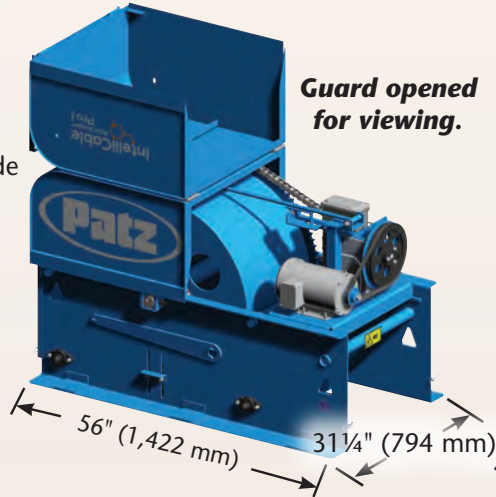

IntelliCable® Pro II

- ¾-hp electric motor
- Efficient 376:1 planetary speed reducer
- #80 roller chain drive
- 27½" (699 mm) diameter drive drum - 18½" (470 mm) wide
- 2 cable over wrap switches
- 3/8", 7/16", & 1/2" O.D. cable
- Safety interlocks
- External bearings with grease fittings
- Sensor disc and proximity sensors

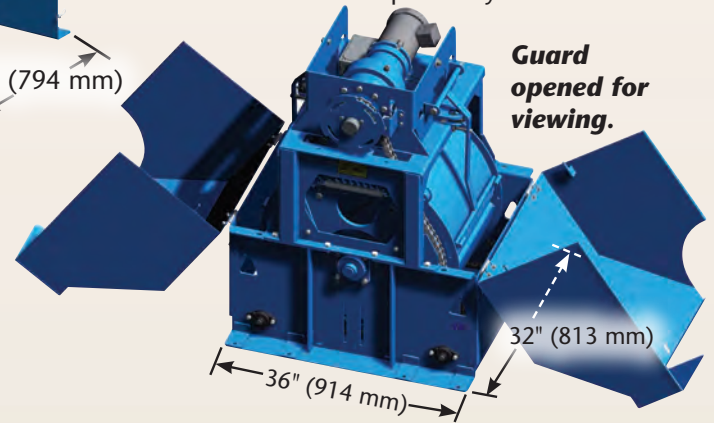

IntelliCable® Pro III

- ¾-hp electric motor
- Efficient 376:1 planetary speed reducer
- #80 roller chain drive
- 56" (1,422 mm) diameter drive drum - 18½" (470 mm) wide
- 2 cable over wrap switches
- 3/8", 7/16", & 1/2" O.D. cable
- Safety interlocks
- External bearings with grease fittings
- Sensor disc and proximity sensors

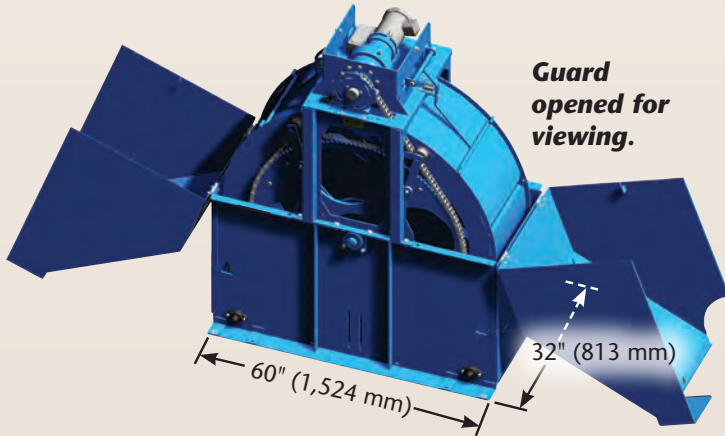

Max. Scraped Alley Length (SAL) & Max. Total Circuit Length (TCL) w/4 Scrapers	Pro I ft. (m)	Pro II ft. (m)	Pro III ft. (m)
SAL with 1/2" Cable	220 (67)	215 (66)	440 (134)
SAL with 7/16" Cable	255 (78)	250 (76)	510 (155)
SAL with 3/8" Cable	285 (87)	280 (85)	570 (174)
TCL with 1/2" Cable	650 (198)	850 (259)	1,760 (536)
TCL with 7/16" Cable	800 (244)	1,000 (305)	2,040 (622)
TCL with 3/8" Cable	900 (274)	1,100 (335)	2,280 (695)

Keep your livestock clean and healthy by installing the IntelliCable® Alley Scraper, a part of the



Sensor Control



Drive unit design includes sensor disc and proximity sensors to provide the control panel with necessary information to keep track of scraper's position and direction.

Self-Locking Ratchet System



The self-locking ratchet system allows easy tightening of cable.

Customize your IntelliCable® Alley Scraper to fit your operation!

Corner Wheel



Cover removed for viewing.

Patz Proven Performer Corner Wheel

The 16" (406 mm) diameter cast iron corner wheels feature stainless steel fasteners as standard components. Corner wheels accept 3/8", 7/16", or 1/2" cable. Phenolic with graphite sleeve bearings for longer life.

Folding V Scraper

- Low-profile scraper wings and folding design allow easy passage for animals, tractors, and skid-steer loaders when bedding freestalls.
- Replaceable wings available for easy servicing.
- Cleans alleys with widths from 64 to 174 inches (1.6-4.4 m).



Folding Angled Tip-Up Scraper

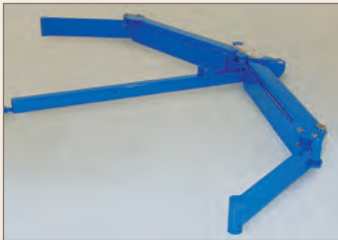

- Wings pivot to follow wall tightly for better cleaning.
- During the reverse movement, blades tip up and wings pivot inward.
- Heavy enough to clean better; extra steel in wear points.
- Cleans alleys with widths from 84 to 192 inches (2.1-4.9 m).

- Replacement blades and wings available for easy servicing.
- Scraper removes easily – center in slot and lift off.
- Scraper can be replaced without removing sled.

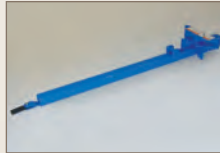

Versa Folding V Scraper

- Low-profile scraper wings and folding design allow easy passage for animals, tractors, and skid-steer loaders when bedding freestalls.
- Cleans alleys with widths from 64 to 174 inches (1.6-4.4 m).
- Optional choice of three economical, replaceable, bolt-on blade edges:
 - AR400 STEEL for use with sand bedding.
 - RUBBER for use with rubber mat floors.
 - URETHANE for use with rubber mat floors or concrete (where floor wear is a concern) and sand bedding. This is a great alternative material for longer wear.
- Universal scraper wings are replaceable.



Sleds

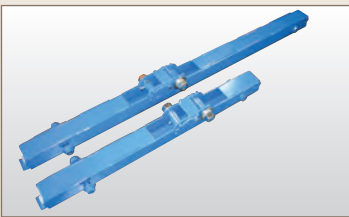

57" (1,448 mm) sleds provide better scraper stability. 37" (940 mm) sleds are available where a shorter sled is required.

For Rubber Flooring

Hard nylon rollers located on sled ends and scraper arms position the scraper above the rubber covered alleys, ensuring only rubber blades touch rubber flooring.

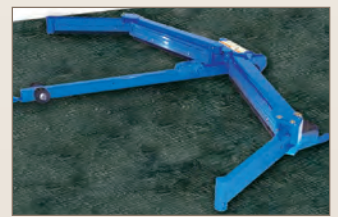

CAUTION: Never operate Patz equipment without all shields and guards in place. Safety is no accident. Before operating any piece of equipment, be sure to read and understand the operator's manual. This manual should be kept with the machine at all times. Additionally, make sure all safety shields and devices are functioning properly and are securely in place.



For some photos in this brochure, guards were removed for photographic purposes only to allow viewing of the equipment features. Before operating equipment, all guards must be in place. Because Patz continually improves and updates products, Patz reserves the right to change the construction of machines or attachments or any part thereof without incurring any obligation to make like changes on Patz machines, or attachments previously delivered. Specifications and prices subject to change without notice.

Proven Performance You Can Count On!

Patz Corporation

917 Business 141, POB 7 • Pound, Wisconsin 54161-0007

Ph: (920) 897-2251 • Fax: (920) 897-2142

www.patzcorp.com • info@patzcorp.com

PA-26731 Rev. 11/14 ©2013-2014 Patz Corporation Printed in U.S.A.



The name generations
of farmers have
entrusted with their
feed and manure
handling needs!