

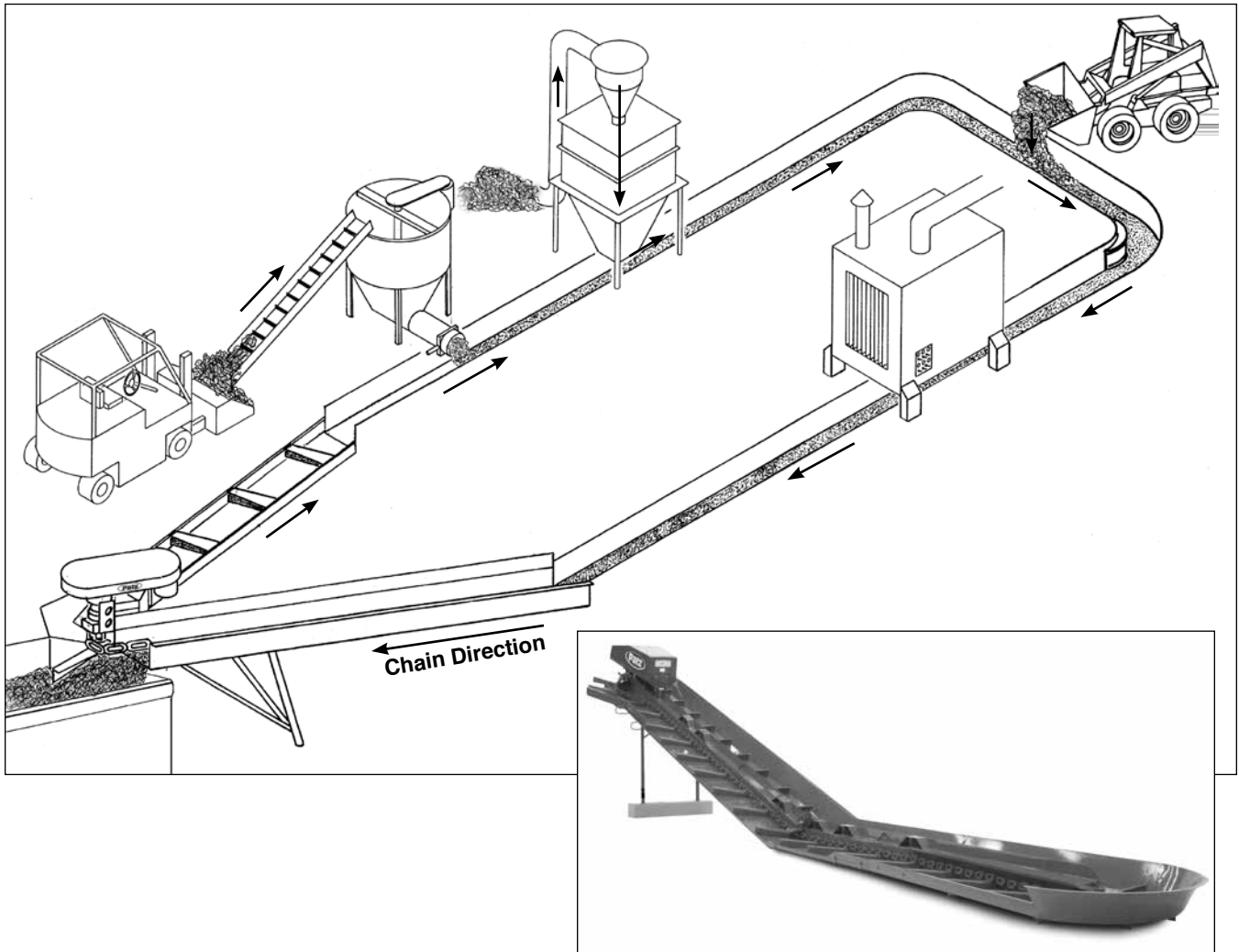

# Model 400 Material Mover

## Technical Data and Layout Planner



Due to continual updating, design and specifications are subject to change without notice.

Patz Corporation  
P.O. Box 7  
Pound, WI 54161  
TEL: (920) 897-2251  
FAX: (920) 897-2142  
info@patzcorp.com  
www.patzcorp.com

# Standard Equipment Specifications

- Overall Lengths:** 20' (6.096 m) to 200' (60.96 m). (Max. 400' (152.4 m) chain length depending on load and configuration.)
- Construction:** All steel; slide is High-Strength, Corrosion Resistant steel.
- Chain:** Model 400 hook-and-eye, all steel link, progression forged; heat treated.
- Flites:** Model 467: 4" (102 mm) high at tip, 1/4" (6.4 mm) thick, all steel, 1/2" (12.7 mm) wear shoe welded to bottom.  
Model 447: 2" (51 mm) high, 1/4" (6.4 mm) thick, all steel, 2 x 3 x 1/2" wear shoe welded to bottom.
- Steel Trough and Concrete Gutter width:** 18" (457 mm).
- Planetary Gear Drive:** Planetary speed reducer with 12, 18, 24, 30 and 36 ft/min (3.7, 5.5, 7.3, 9.1 and 11 m/min) chain speed; 2, 3, 5 or 7-1/2 H.P. motor.
- Heavy Roller Chain Drive:** V-belt and single-strand final drive roller chain reducer with 18 or 30 ft/min (5.5 or 9.1 m/min) chain speed; maximum 5 H.P. motor.
- 203SMTP Gearbox reducer drive:** 24 or 36 ft/min (7.1 or 11 m/min) chain speed; 2 or 3 H.P. motor.
- Load Capacity:** Up to 45 ft<sup>3</sup>/min (1.274 m<sup>3</sup>/min), at 36 ft/min (11 m/min) depending on gutter width and depth, elevation and type of material moved. (Through trapdoor, 25 ft<sup>3</sup>/min (0.708 m<sup>3</sup>/min))
- Span:** Up to 20' (6.096 m) between supports.
- Color:** Blue baked-on-polyester powder coat and epoxy polyester finish.
- Electrical Controls:** Customer supplied.
- Assembly:** Conveyor supplied unassembled.

# Optional Equipment Specifications

- Options:** Flite wiper brushes material off flites; stands for support; trapdoor to drop material out bottom of trough; covers for troughs; corner sections; stainless steel slide; double corner wheels for smoother operation under heavier loads; steel liner for concrete trough provides a smooth surface.
- Drive Motors:** 2, 3, 5 or 7-1/2 H.P., 1 ph. or 3 ph.

# Calculating Capacity

Capacity and HP requirements can vary depending on the material moved, inclines involved and many other factors. Consideration must be given to the machine layout, incline, elbows, chain length and speed, as well as material density, moisture content, and frictional characteristics of the material to be moved. Use caution when material unit weights exceed 40 lbs. per cu. ft. (640.7 kg/m<sup>3</sup>) as material depth in troughs should not exceed 2-4 inches (50.8-101.6 mm). Slanted side walls may reduce capacity, but should be used with rigid materials such as wood blocks or bark to avoid bending flites.

## EXAMPLE

- 1) Convert to lbs./min.
- 2) Divide by material unit weight to determine volume.
- 3) Refer to Volume Capacity Table for material delivery rate at an estimated depth in trough.

U.S. UNITS	METRIC UNITS
M-400 Material Mover, moves 15 ton/hour, wood chips at 30 lbs/cu. ft.	M-400 Material Mover, moves 13.61 t/hr, wood chips at 480.5 kg/m <sup>3</sup> .
1) $\frac{15 \text{ T}}{\text{hr.}} \times \frac{2000 \text{ #}}{\text{T}} \times \frac{\text{hr.}}{60 \text{ min.}} = 500 \text{ # /min.}$	1) $13.61 \text{ t/hr} \times \frac{1000 \text{ kg}}{\text{t}} \times \frac{\text{hr.}}{60 \text{ min.}} = 226.8 \text{ kg/min.}$
2) $\frac{500 \text{ # / min.}}{30 \text{ # / cu.ft.}} = 16.7 \text{ ft}^3/\text{min.}$	2) $\frac{226.8 \text{ kg/ min.}}{480.5 \text{ kg/m}^3} = 0.47 \text{ m}^3/\text{min.}$
3) 6" material depth at 24 FPM gives 18 ft <sup>3</sup> /min. delivery (from table).	3) 152.4 mm material depth at 7.3 m/min gives 0.510 m <sup>3</sup> /min. delivery (from table).

## VOLUME CAPACITY TABLE

Material Depth (Inches)	Volume of Matl. per Running ft ft <sup>3</sup> /min (m <sup>3</sup> /min.)	MATERIAL DELIVERED PER MINUTE ( 18" (457 mm) WIDE TROUGHS)				
		VOL. @ 12 ft/min (3.7 m/min) ft <sup>3</sup> /min (m <sup>3</sup> /min.)	VOL. @ 18 ft/min (5.5 m/min) ft <sup>3</sup> /min (m <sup>3</sup> /min.)	VOL. @ 24 ft/min (7.3 m/min) ft <sup>3</sup> /min (m <sup>3</sup> /min.)	VOL. @ 30 ft/min (9.1 m/min) ft <sup>3</sup> /min (m <sup>3</sup> /min.)	VOL. @ 36 ft/min (11.0 m/min) ft <sup>3</sup> /min (m <sup>3</sup> /min.)
2 (50.8)	.25 (0.007)	3.0 (0.085)	4.5 (0.127)	6.0 (0.170)	7.5 (0.212)	9.0 (0.255)
4 (101.6)	.50 (0.014)	6.0 (0.170)	9.0 (0.255)	12.0 (0.340)	15.0 (0.425)	18.0 (0.510)
6 (152.4)	.75 (0.021)	9.0 (0.255)	13.5 (0.382)	18.0 (0.510)	22.5 (0.637)	27.0 (0.765)
8 (203.2)	1.0 (0.028)	12.0 (0.340)	18.0 (0.510)	24.0 (0.680)	30.0 (0.850)	36.0 (1.020)
10 (254.0)	1.25 (0.035)	15.0 (0.425)	22.5 (0.637)	30.0 (0.850)	37.5 (1.062)	45.0 (1.274)

# Typical Installations

It is the user's responsibility to cover all walkways and return troughs with a steel floor plate to prevent possible personal injury. Cover should extend from hold down post at bottom end of the elevating slide to and including return corner. If no elevating slide is used, trough covers should extend from the drive unit to and including the return corner.

- Right Hand (R.H.)** = Counter-clockwise chain movement.
- Left Hand (L.H.)** = Clockwise chain movement.
- Shaded Portion** = Loaded trough.

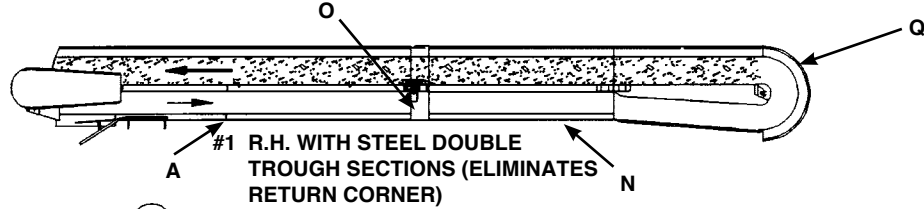

**#1 R.H. WITH STEEL DOUBLE TROUGH SECTIONS (ELIMINATES RETURN CORNER)**

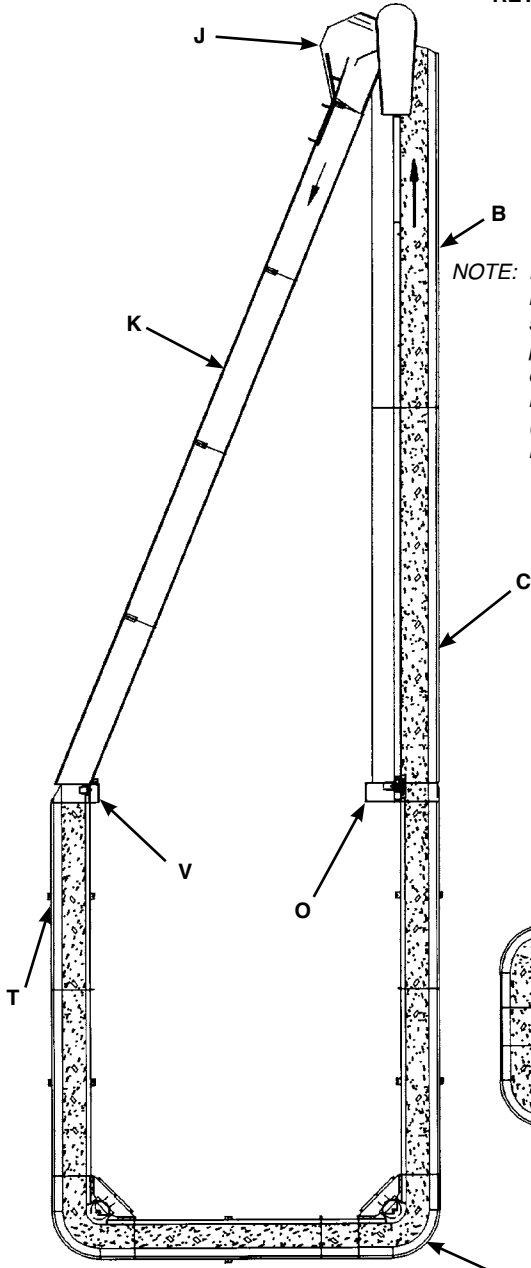

**#2 R.H. WITH STEEL SINGLE TROUGH SECTIONS AND SPLIT CHUTE (ELIMINATES RETURN CORNER).**

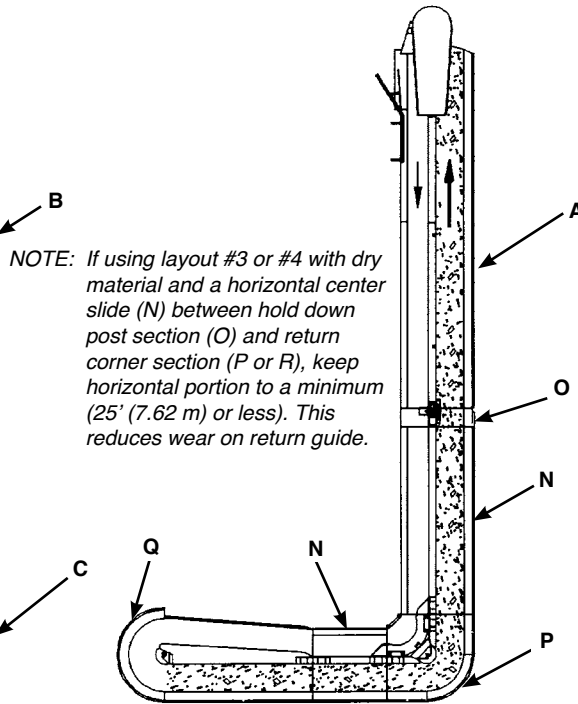

**#3 R.H. WITH STEEL DOUBLE TROUGH SECTIONS AND 90° RETURN CORNER SECTION.**

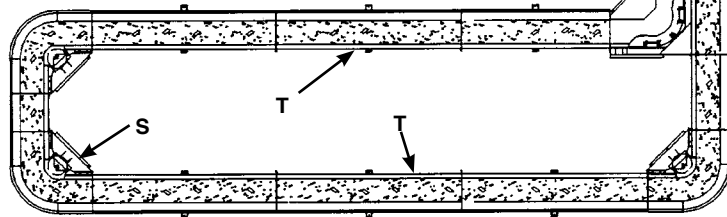

**#4 R.H. WITH COMBINATION DOUBLE AND SINGLE TROUGH SECTIONS AND 90° RETURN CORNER SECTION.**

- N - Center Slide
- O - Hold Down Post Section
- P - 90° Return Corner Section
- Q - 10' 180° End Section
- R - Single Trough 90° Return Corner Assy.
- S - Single Trough 90° Corner Wheel Assy.
- T - Single Trough Section
- U - 8' Hold In Angle
- V - Split Chute Transition Section

# Typical Installations (Con't)

NOTE: The shaded portions indicate where the troughs can be loaded.

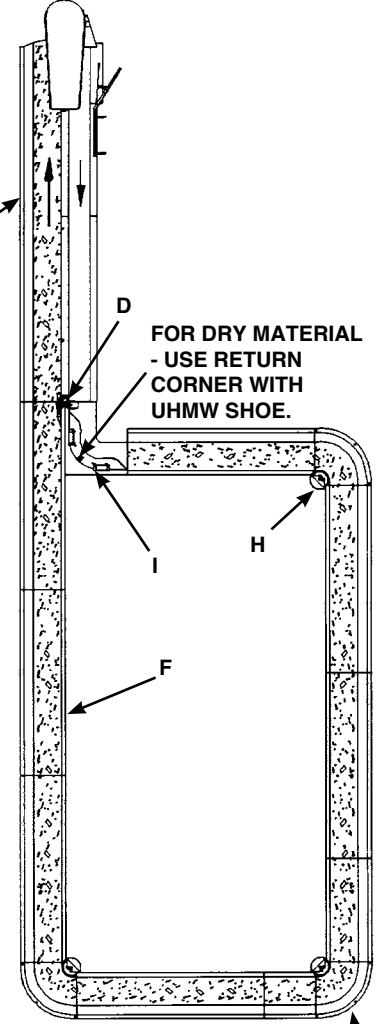
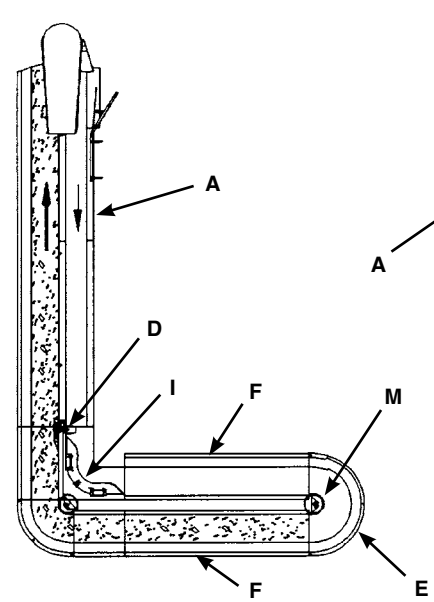
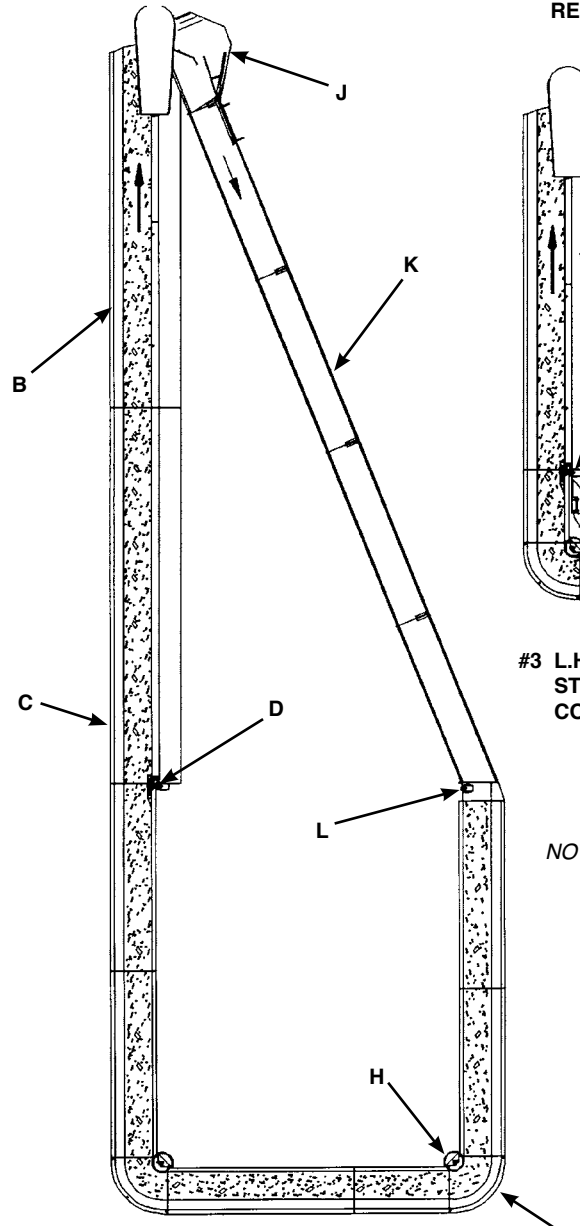
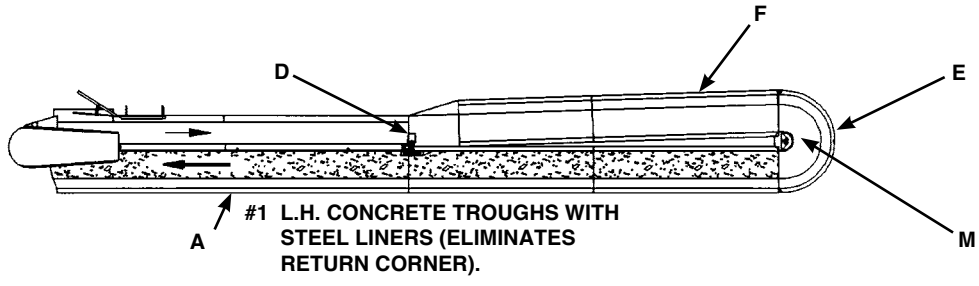

NOTE: If using layout #3 or #4 with dry material and a horizontal section between hold down post (D) and 90° return corner section (I), keep horizontal portion to a minimum (25' (7.62 m) or less). This reduces wear on return shoe.

#2 L.H. CONCRETE TROUGH WITH STEEL LINERS AND SPLIT CHUTE (ELIMINATES RETURN CORNER).

#3 L.H. CONCRETE TROUGH WITH STEEL LINERS AND 90° RETURN CORNER.

#4 L.H. CONCRETE TROUGH WITH STEEL LINERS AND 90° RETURN CORNER.

- A - Slide
- B - Front Slide
- C - Rear Slide
- D - Hold Down Post
- E - 180° Corner Liner
- F - Single Trough Liner
- G - 90° Corner Liner
- H - 90° Corner Wheel Assy.
- I - 90° Return Corner
- J - Split Chute Front Section
- K - Split Chute Return Trough
- L - Split Chute Wear Plate
- M - 180° Corner Wheel Assy.

# Typical Trough Cross Sections

## Above Floor

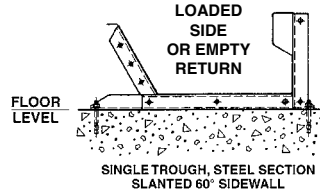
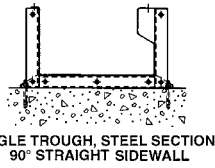
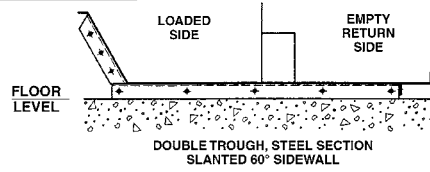
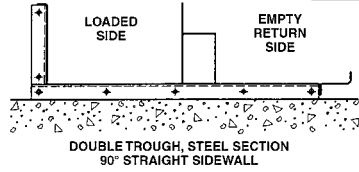

## In Floor

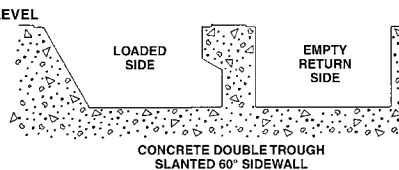
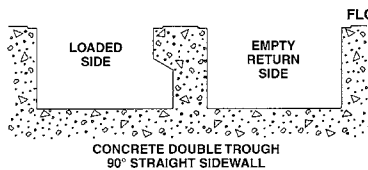
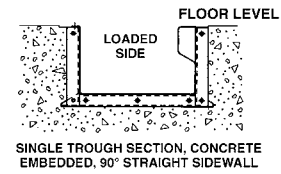
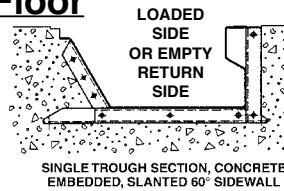
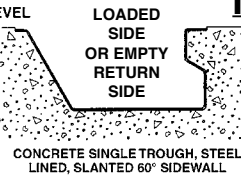
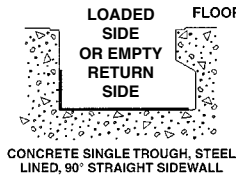

NOTE: Unlined concrete troughs can produce added friction, resulting in increased horsepower requirements, increased wear of the flites, as well as wearing away of the concrete.

# Typical Split Chute Straight Pull, Right Hand Installation

**IMPORTANT:** Maximum split chute angle 22° to allow sufficient chain wrap for proper operation, dimensions given reflect that maximum angle.

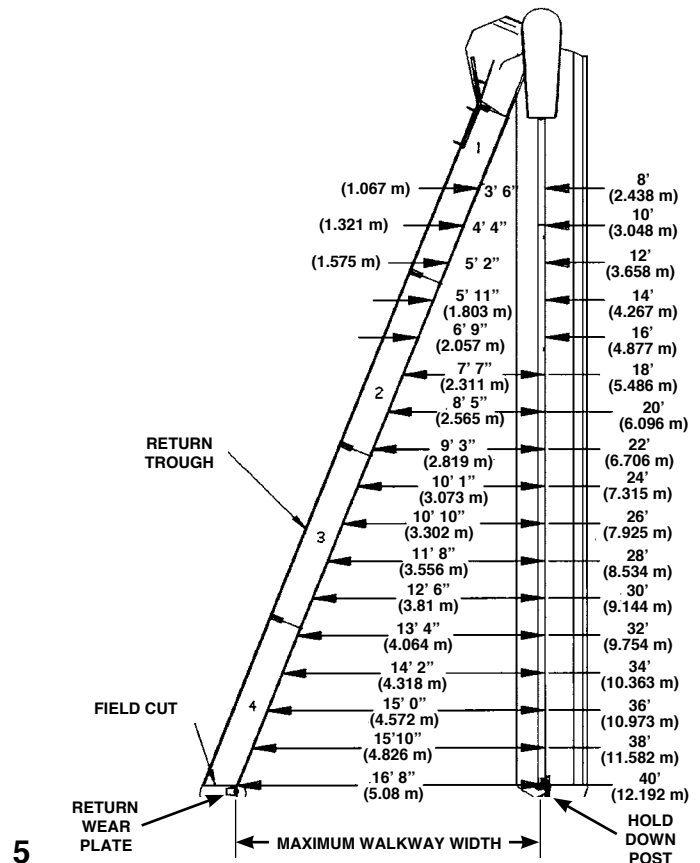

# Dimensions

## SINGLE TROUGH, STEEL, SLANTED 60° AND 90° STRAIGHT SIDEWALL BOLT-TOGETHER SECTIONS

### Single Trough Slanted 60° Sidewall (End View)

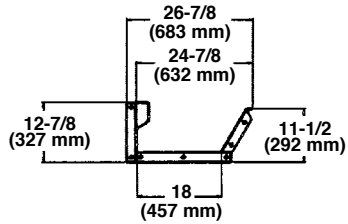

Available in 1', 2', 4', 10' Lengths.

### Single Trough 90° Straight Sidewall (End View)

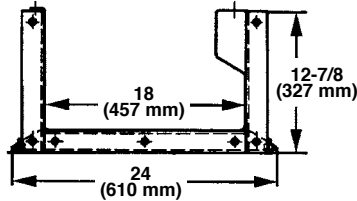

Available in 1', 2', 4', 10' Lengths.

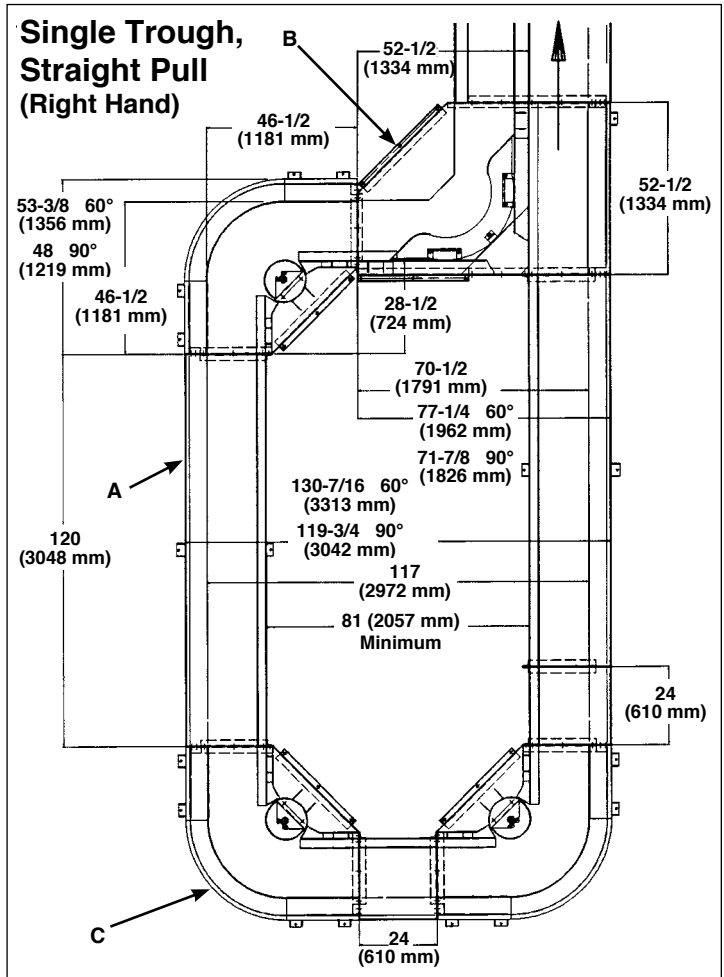

- A - Single Trough Section
- B - Single Trough 90° Return Corner Assy.
- C - Single Trough 90° Corner Wheel Assy.

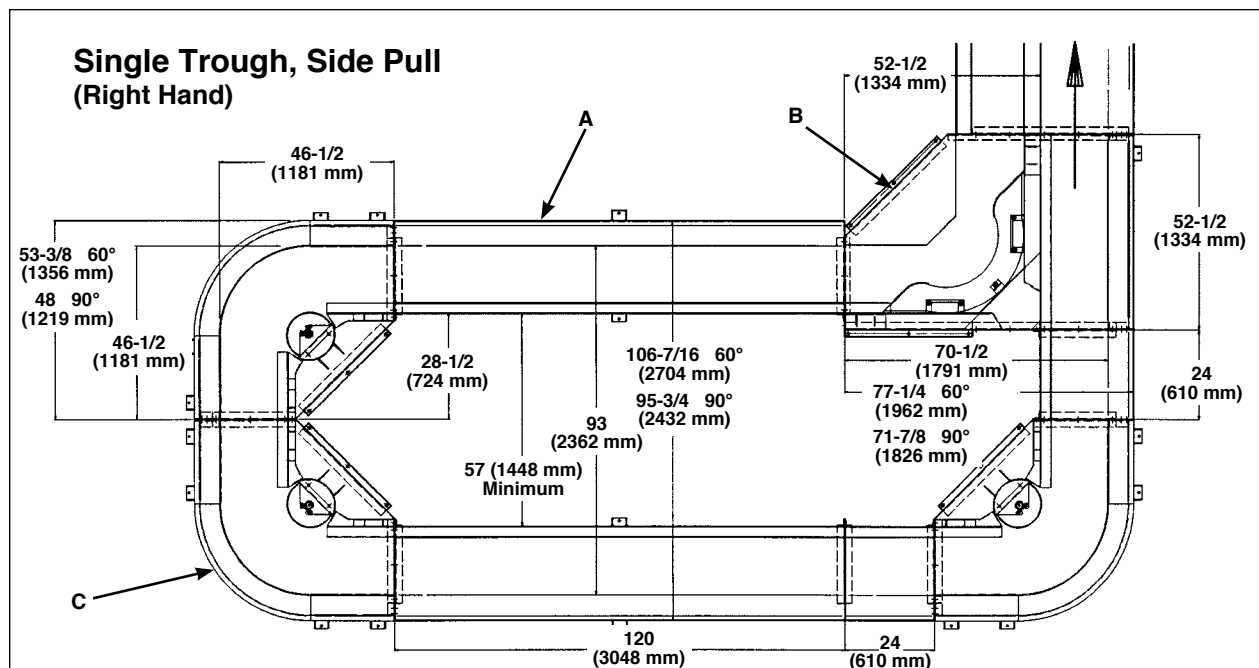

# Dimensions

## DOUBLE TROUGH, STEEL, SLANTED 60° SIDEWALL BOLT-TOGETHER SECTIONS

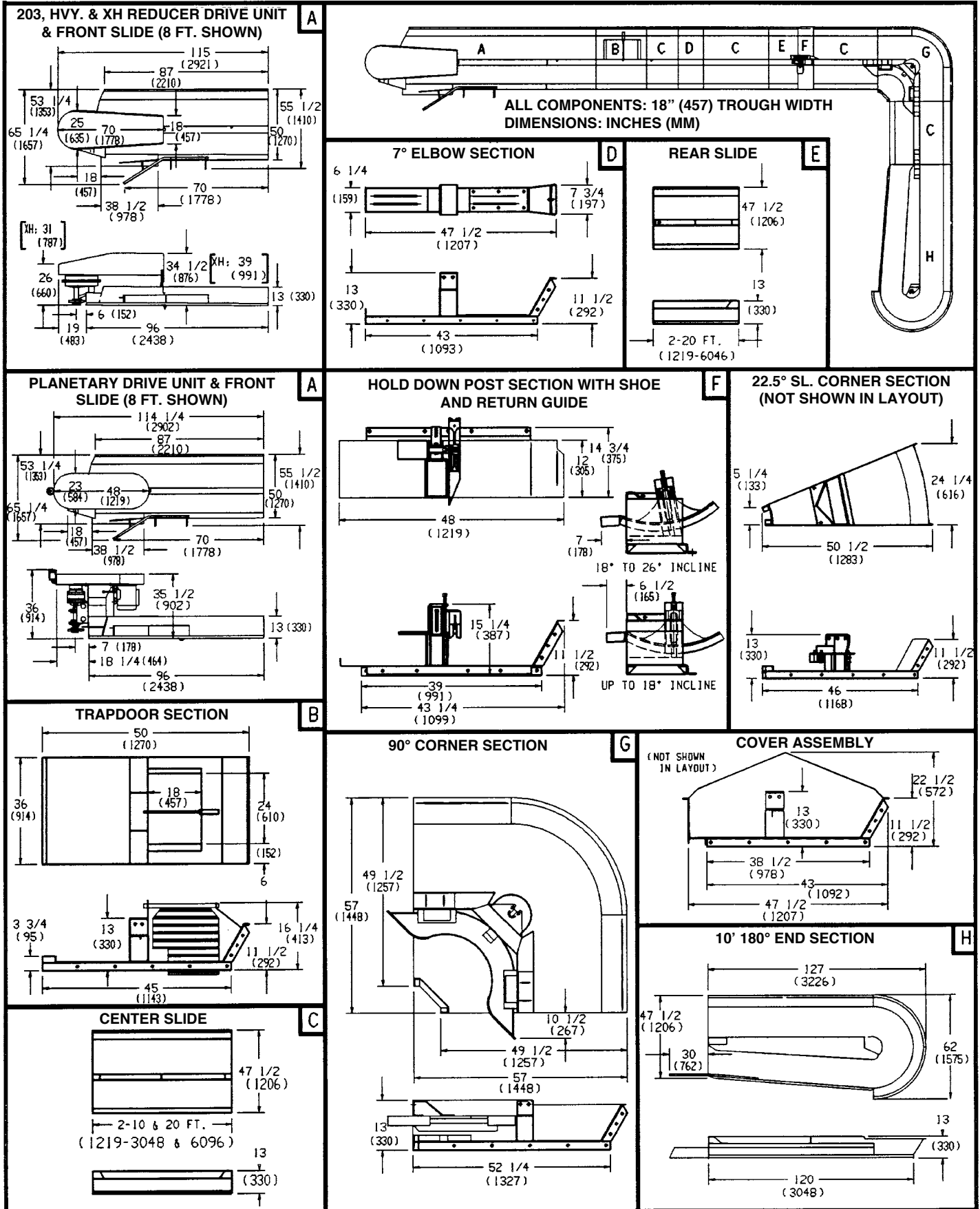

# Dimensions

## DOUBLE TROUGH, STEEL, 90° STRAIGHT SIDEWALL BOLT-TOGETHER SECTIONS

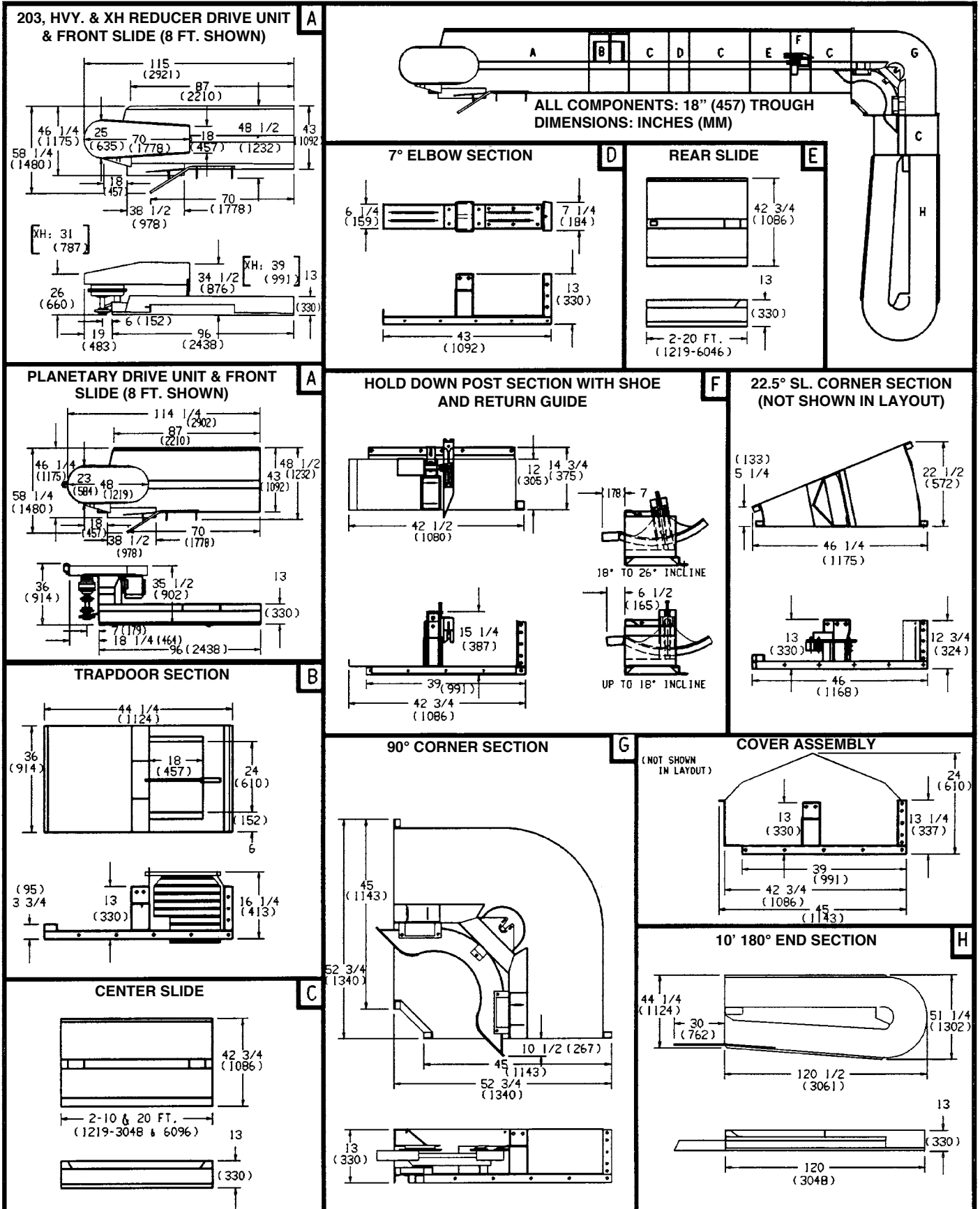



Dealer/Distributor: \_\_\_\_\_

Address: \_\_\_\_\_

Phone: \_\_\_\_\_

Fax: \_\_\_\_\_

E-mail: \_\_\_\_\_

Customer: \_\_\_\_\_

Address: \_\_\_\_\_

Phone: \_\_\_\_\_

Fax: \_\_\_\_\_

E-mail: \_\_\_\_\_

Date: \_\_\_\_\_

By: \_\_\_\_\_

**Proposed Layout:**

1/4" = \_\_\_\_\_ ft.

